**SLOVENIAN TRAFFIC SAFETY AGENCY,
KOTNIKOVA ULICA 19a,
1000 LJUBLJANA,
SLOVENIA**

We, Akrapovič d.d., Malo Hudo 8a. 1295 Ivančna Gorica, Slovenia hereby ask STSA (to apply an extension of *e26*134/2014*2018/295G*08207*00*), to grant an extension to an approval against ***e26*134/2014*2023/2724G*08207*01*** for the following product:

Replacement Exhaust system for Motorcycles-muffler:

Type: ***M-HJM001***

Version: ***M-HJM001 01SS (SS / SS / SS)***

Manufacturer: ***Akrapovič d.d.
Malo Hudo 8a
1295 Ivančna Gorica
Slovenia***

We declare that we have not applied to any other Approval Authority in the EU Member States for this approval.

We have requested ***TÜV SÜD Auto Service GmbH***, to carry out all testing required by the directive and/or regulation that the approval is sought against and to present the entire documentation for the approval.

Yours sincerely,

Date: 15.04.2025

Akrapovič d.d.
Davorin Dobočnik, CEO

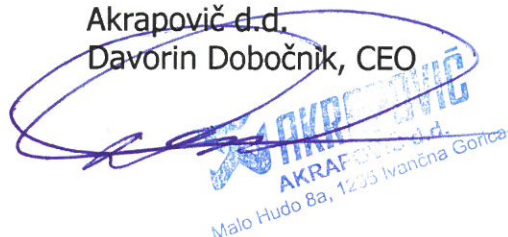

AKRAPOVIČ
Malo Hudo 8a, 1295 Ivančna Gorica



**PRÜFBERICHT
ERWEITERUNG 01
TEST REPORT
EXTENSION 01**

Nr. / no. 23-00043-CM-GBM-01

über die Prüfung zur Bauartgenehmigung einer Nicht-Originalauspuffanlage oder von Einzelteilen hiervon als selbstständige technische Einheit für Krafträder /

about a test regarding a component type-approval for non-original exhaust system or components thereof, as a technical unit for motorcycles

Verordnung / Regulation (EU) 134/2014 vom / dated 16.12.2013
zuletzt geändert / last amended (EU) 2023/2724 vom / dated 27.09.2023
Kodierung / Codification G

zur Ergänzung der Verordnung (EU) Nr. 168/2013 des Europäischen Parlaments und des Rates. /
supplementing Regulation (EU) 168/2013 of the European Parliament and the Council.

Genehmigungsstand / Approval status

<input type="checkbox"/>	Erteilung einer Typgenehmigung <i>Granting of a type approval</i>
<input checked="" type="checkbox"/>	Nachtrag/Änderung zur Typgenehmigung Nr. e26*134/2014* 2018/295G *08207* 00 (alt / old) <i>Extension/correction to type approval no. e26*134/2014*2023/2724G*08207*01 (neu / new)</i>

Gründe der Erweiterung / Reasons for extension

Es wird geändert /
It will be changed:

- Der Verwendungsbereich wird erweitert /
Extension of application range

Es wird aktualisiert /
It will be updated:

- Anlage 2/01 / *Enclosure 2/01*
- Richtlinienstand / *Level of directive*
- Zusammenbauzeichnung /
Assembly drawing



0. Allgemeine Angaben / General information

- 0.1. Fabrikmarke / Make: AKRAPOVIČ
0.2. Typ / Type: M-HJM001
0.2.1. Ausführungen / Variants:

Ausführungen / Variants	Material / Material		
	Rohre / Tubes	Außenmantel / Sleeve	Endkappe / End cap
M-HJM001 01SS	VA / Stainless steel	VA / Stainless steel	VA / Stainless steel

Die Ausführungen unterscheiden sich in der Verwendung verschiedener Werkstoffe. Der konstruktive Aufbau ist gleich. Das akustische Verhalten ist als gleichwertig zu betrachten. /

The variants vary because different materials are used. The basic construction remains the same. The acoustic behaviour is to be regarded as equivalent.

- 0.3. Name und Anschrift des Herstellers /
Name and address of manufacturer: Akrapovič d.d.
Malo Hudo 8a
SLO-1295 Ivančna Gorica
- 0.4. Name und Anschrift des Beauftragten /
Name and address of authorized agent: entfällt / n.a.
- 0.5. Nr. des Beschreibungsbogens /
No. of information document: M-HJM001
Ausgabedatum / *Date:* 06.06.2025

1. Verwendungsbereich / Application range

- 1.1. Klasse der Fahrzeuge für die die
Anlage bestimmt ist /
Class of the vehicles the unit is used for: L3e
- 1.2. Beschreibung der Fahrzeuge für
die die Einrichtung bestimmt ist /
*Description of the vehicles
the unit is used for:* siehe Anlage 2/01 / see enclosure 2/01

2. Angaben zum Prüfobjekt / Composition of the separate technical unit

- 2.1. Art der Technischen Einheit /
Kind of technical unit: unverändert / without changes
- 2.2. Ort der Kennzeichnung /
Place of marking: unverändert / without changes
- 2.3. Zusammenstellung der techn. Einheit /
Composition of the separate technical unit: siehe Anlage 1/01 / see enclosure 1/01
- 2.4. Lage und Richtung der Auspuffmündung /
Position and direction of the tail pipe: unverändert / without changes

3. Prüfprotokoll / Test report

Auf eine erneute Prüfung konnte verzichtet werden, da die neu hinzugekommenen Fahrzeuge serienmäßig mit der gleichen Schalldämpferanlage ausgerüstet sind und gleiche bzw. geringere Motorleistung besitzen. /
New testing of the replacement silencer wasn't necessary because the new vehicles have in original the same exhaust system and same or lower maximum engine power.

4. Anlagen / Enclosures

Anlage 1/01: Teile der technischen Einheit (1 Seite / Page)
Enclosure 1/01: Composition of the separate technical unit

Anlage 2/01: Verwendungsbereich (2 Seiten / Pages)
Enclosure 2/01: Field of application

5. Schlussbescheinigung / Summary

Das beschriebene Prüfobjekt entspricht der genannten Prüfspezifikation. Das Prüfobjekt wurde als ungünstigster Fall entsprechend der Prozessbeschreibung "Anforderungen an Prüfberichte (AS-PB-T-02)" aus der Beschreibung des Typs (Beschreibungsmappe) ausgewählt. Somit erfüllt auch der beschriebene Typ die o. a. Prüfspezifikation.

In Bezug auf die Einhaltung der Grenzwerte wurde die Messunsicherheit nicht berücksichtigt.

Der Hersteller trägt die Verantwortung für die zu Verfügung gestellten Informationen und Prüfmuster. Die Prüfergebnisse beziehen sich auf die erhaltenen und genannten Prüfmuster. Diese sind repräsentativ für den beschriebenen Typ.

Der Prüfbericht darf nur vom Auftraggeber und nur in vollem Wortlaut vervielfältigt und weitergegeben werden. Eine auszugsweise Vervielfältigung und Veröffentlichung des Prüfberichtes sind nur nach schriftlicher Genehmigung zulässig. /

5. Schlussbescheinigung (Fortsetzung) / Summary (continuation)

The test object described conforms to the mentioned test specification. The worst-case configuration was selected from the type of description (information folder) in accordance with the process description "Requirements for Test Reports (AS-PB-T-02)". Thus, the described type conforms to the test specification.

In question of meeting the limits the measurement uncertainty was ignored.

The manufacturer is responsible for the information and the test specimens provided by him. The test results relate only to the test specimens as received and mentioned. The test specimens are representative for the type described.

The test report may be reproduced and published in full and by the client only. It can be reproduced partially with the written permission of the test laboratory only.

TÜV SÜD Auto Service GmbH ist benannt als Technischer Dienst durch:

TÜV SÜD Auto Service GmbH is designated as Technical Service by:

Genehmigungsbehörde <i>Approval authority</i>	Land <i>Country</i>	Registriernummer <i>Registration number</i>
Kraftfahrt-Bundesamt (KBA)	Deutschland <i>Germany</i>	KBA-P 00100-10
Vehicle Certification Agency (VCA)	Vereinigtes Königreich <i>United Kingdom</i>	VCA-TS-006
Approval Authority of the Netherlands (RDW)	Niederlande <i>The Netherlands</i>	RDWT-082-xx
National Standards Authority of Ireland (NSAI)	Irland <i>Ireland</i>	49
Swedish Transport Agency (STA)	Schweden <i>Sweden</i>	TT 0024
Société Nationale de Certification et d'Homologation s.a.	Luxemburg <i>Luxembourg</i>	13/B(g)
Vehicle Safety Certification Center (VSCC)	Taiwan <i>Taiwan</i>	DE04-06-2

Dieser Bericht umfasst Seite 1 bis 4. /
This test report contains the pages 1 up to 4.

München, 06.06.2025



F. Rinske (B. Eng.)
Sachverständiger / *Recognized Expert*

fr
M-HJM001_SLO_EC_01.doc



Prüfbericht Nr. / Test report No.: 23-00043-CM-GBM-01
Hersteller / Manufacturer: Akrapovič, d.d., SLO-1295 Ivančna Gorica
Typ / Type: M-HJM001



ANLAGE 1/01 ENCLOSURE 1/01

Teile der technischen Einheit / Composition of the separate technical unit

Lfd. Nr. / No.	Einzelteile, Abmessungen in mm / <i>Components parts, dimensions in mm</i>	Abmessungen des Teiles in mm bzw. Originalteil / Ersatzteil / <i>Dimensions of the part in mm or original part / replacement part</i>	Teilenummer bzw. Genehmi- gungsnummer / <i>Part no. or homologation no.</i>
1)	Krümmerröhr mit Katalysatoren / <i>Header pipe with catalytic converters</i>	Originalteile / <i>Original parts</i>	-
2a)	Schalldämpfer / <i>Silencer</i> (Eintrittsrohr / <i>Inlet pipe</i> Ø 79 Austrittsrohr / <i>Outlet pipe</i> Ø 28)	276 x 201 x 214 lg	M-HJM001 e26*08207*G E26 92R-02 8207

M-HJM001_SLO_EC_11.doc

Prüfbericht Nr. / Test report No.: 23-00043-CM-GBM-01
 Hersteller / Manufacturer: Akrapovič, d.d., SLO-1295 Ivančna Gorica
 Typ / Type: M-HJM001



ANLAGE 2/01
ENCLOSURE 2/01

Verwendungsbereich / Field of application

Die Fahrzeuge erfüllen - bezugnehmend auf ihre Fahrzeugtypgenehmigung - die Umwelthanforderungsstufen:
 The vehicles fulfil - regarding their Whole Vehicle Type Approval (WVTA) - the environmental steps:

Euro (5/5+)
 Euro (5/5+)

Lfd. Nr. Fahrzeug	Hersteller	Fabrikmarke	Handelsbezeichnung	Fahrzeugtyp und Genehmigungsnummer	Var. Vers.	Motortyp 4-Takt	Hubraum in cm ³	Nennleistung kW/min ⁻¹	Sonstige bestimmende Merkmale	Anordnung entspr. Anlage 1/01 lfd. Nr.
No. of vehicle	Manufacturer	Trade mark	Commercial description	Vehicle type and no. of homologation	Var. Vers.	Engine type 4-stroke	Engine capacity in cm ³	max. engine power kW/min ⁻¹	Additional remarks	Composition as shown in enclosure no. 1/01
1)	KTM (A)	KTM	KTM 390 Duke	KTM IS Dk e1*168/2013*00360*	alle / all	963	399	33/8500	mit Kat. / with cat. *)	1)2a)
2)			KTM 250 Duke			962		23/9500		
3)			KTM 125 Duke	KTM IS Dk e1*168/2013*00359*		960	125	11/10000		
4)		Husqvarna	Svartpilen 401	IS HQV e1*168/2013*00362*		963	399	33/8500		
5)			Svartpilen 250			962		23/9500		
6)			Vitpilen 401			963		33/8500		

Prüfbericht Nr. / Test report No.: 23-00043-CM-GBM-01
 Hersteller / Manufacturer: Akrapovič, d.d., SLO-1295 Ivančna Gorica
 Typ / Type: M-HJM001



ANLAGE 2/01
ENCLOSURE 2/01

Verwendungsbereich / Field of application

Lfd. Nr. Fahrzeug	Hersteller	Fabrikmarke	Handelsbezeichnung	Fahrzeugtyp und Genehmigungsnummer	Var. Vers.	Motortyp 4-Takt	Hubraum in cm ³	Nennleistung kW/min ⁻¹	Sonstige bestimmende Merkmale	Anordnung entspr. Anlage 1/01 lfd. Nr.
No. of vehicle	Manufacturer	Trade mark	Commercial description	Vehicle type and no. of homologation	Var. Vers.	Engine type 4-stroke	Engine capacity in cm ³	max. engine power kW/min ⁻¹	Additional remarks	Composition as shown in enclosure no. 1/01
7)	KTM (A)	KTM	KTM 390 Adventure	KTM IS ADV e1*168/2013*00416*	alle / all	963	399	33/8500	mit Kat. / with cat. *)	1)2a)
8)			KTM 390 Adventure R							
9)			KTM 390 Adventure X							
10)			KTM 250 Adventure	962		249	23/9500			
11)			KTM 125 Enduro	KTM IS ENDSM e1*168/2013*00410*		960	125	11/10000		
12)			KTM 125 SMC R							
13)			KTM 390 Enduro	KTM IS ENDSM e1*168/2013*00411*		963	399	33/8500		
14)			KTM 390 SMC R							

*) Der serienmäßige Katalysator bleibt unverändert im Abgassystem. Eine Verschlechterung des Abgasverhaltens ist nicht zu erwarten. /
 The original catalytic converter remains in the exhaust system. A degradation of catalyst efficiency is not expected.

M-HJM001_SLO_EC_21.doc

Information Document M-HJM001

relating to EU type-approval of a noise-abatement device as a STU

TÜV SÜD Auto Service Technical Report: 23-00043-CM-GBM-01

Item No.	(Sub) categories	Detailed information
B.		General information concerning systems, components, or separate technical units
0.7.	L1e — L7e	Make(s) (trade name(s) of manufacturer): AKRAPOVIC
0.8.	L1e — L7e	Type: M-HJM001
0.8.1.	L1e — L7e	Commercial name(s) (if available): n.a.
0.8.2.	L1e — L7e	Type-approval number(s) (if available): e26*134/2014*2023/2724G*08207*01
0.8.3.	L1e — L7e	Type-approval(s) issued on (date, if available): n.a.
0.9.	L1e — L7e	Company name and address of manufacturer: Akrapovic d.d. Malo Hudo 8a SLO-1295 Ivancna Gorica
0.9.1.	L1e — L7e	Name(s) and address(es) of assembly plants: Akrapovič, d.d. Malo Hudo 8a SLO-1295 Ivancna Gorica Akrapovič d.d., PE Ulica heroja Stariha 24 SLO-8340 Črnomelj
0.9.2.	L1e — L7e	Name and address of manufacturer's authorized representative, if any: n.a.
0.10.		Vehicle(s) for which the system/separate technical unit is intended for:
0.10.1.	L1e — L7e	Type: see Technical Report
0.10.2.	L1e — L7e	Variant: see Technical Report
0.10.3.	L1e — L7e	Version: see Technical Report
0.10.4.	L1e — L7e	Commercial name(s) (if available): see Technical Report
0.10.5.	L1e — L7e	Category, subcategory and sub-subcategory of vehicle: see Technical Report
C.		General information concerning vehicle, systems, components, or separate technical units
0.12.		Conformity of production
0.12.1.	L1e — L7e	Controlled by ISO 9001:2008 Quality Management System certified by TÜV SÜD Management Service GmbH Registration no.: 12 100/104 31148 TMS
1.		GENERAL CONSTRUCTION CHARACTERISTICS
1.8.		Propulsion unit performance
1.8.1.	L3e, L4e, L5e, L7e-A, L7e-B2	Declared maximum vehicle speed: km/h see Technical Report
1.8.2.	L1e, L2e, L6e, L7e-B1, L7e-C	Maximum design vehicle speed: and gear in which it is reached: n.a.
1.8.3.	L1e — L7e	Maximum net power combustion engine: . kW at . min ⁻¹ at A/F ratio: see Technical Report
1.8.4.	L1e — L7e	Maximum net torque combustion engine: . Nm at . min ⁻¹ at A/F ratio: see Technical Report
1.8.5.	L1e — L7e	Maximum continuous-rated power electric motor (15/30 minutes power): n.a.
1.8.6.	L1e — L7e	Maximum continuous-rated torque electric motor: Nm at min ⁻¹ n.a.
1.8.7.	L1e — L7e	Maximum continuous total power for propulsion(s): kW. at ... min ⁻¹ at A/F ratio: n.a.
1.8.8.	L1e — L7e	Maximum continuous total torque for propulsion(s): Nm at min ⁻¹ at A/F ratio: n.a.
1.8.9.	L1e — L7e	Maximum peak power for propulsion(s): kW at min ⁻¹ at A/F ratio: n.a.

4.		GENERAL INFORMATION ON ENVIRONMENTAL AND PROPULSION UNIT PERFORMANCE
4.0		General information on environmental and propulsion performance
4.0.1.	L1e — L7e	Environmental step: Euro (5/5+)
4.0.2.	L1e — L7e	Fuel consumption: see WVTA
4.0.3.	L1e — L7e	CO ₂ emissions: see WVTA
4.0.4.	L1e — L7e	Energy consumption: n.a.
4.0.5.	L1e — L7e	Electric range: n.a.
4.0.6.		Sound level
4.0.6.1.	L1e — L7e	Limit value for L _{urban} : see Technical Report
4.4.	L1e — L7e	Additional information on environmental and propulsion unit performance
4.4.4.	L1e — L7e	All additional technical information according to UN Regulation No. 92, are mentioned in the Technical Report or shown in the attachments.

Anlage / Enclosure	Dokument-Nr. / Document no.	Datum / Date	Seiten / Pages
Zeichnung Gesamtanlage / Drawing exhaust system	KTM 390 Duke	-	1
Zeichnung(en) der Bauteile der zu genehmigenden techn. Einheit / Drawing(s) of the part(s) of the separate techn. unit	siehe vorherige Prüfberichte / see former test reports	-	-
Stückliste / Part list	siehe vorherige Prüfberichte / see former test reports	-	-
Einbauanleitung / Mounting instructions	siehe vorherige Prüfberichte / see former test reports	-	-
ASEP-Erklärung / ASEP Statement	siehe vorherige Prüfberichte / see former test reports	-	-



 Davorin Dobočnik, CEO

06.06.2025

KTM 390 Duke / Partial exhaust system / Slip-ON line / EC & ECE Type approval
KTM 250 Duke / Partial exhaust system / Slip-ON line / EC & ECE Type approval
KTM 125 Duke / Partial exhaust system / Slip-ON line / EC & ECE Type approval
Husqvarna Svartpilen 250 / Partial exhaust system / Slip-ON line / EC & ECE Type approval
Husqvarna Svartpilen 401 / Partial exhaust system / Slip-ON line / EC & ECE Type approval
Husqvarna Vitpilen 401 / Partial exhaust system / Slip-ON line / EC & ECE Type approval
KTM 390 Adventure/R/X / Partial exhaust system / Slip-ON line / EC & ECE Type approval
KTM 390 Enduro / Partial exhaust system / Slip-ON line / EC & ECE Type approval
KTM 390 SMC R / Partial exhaust system / Slip-ON line / EC & ECE Type approval
KTM 250 Adventure / Partial exhaust system / Slip-ON line / EC & ECE Type approval
KTM 125 Enduro / Partial exhaust system / Slip-ON line / EC & ECE Type approval
KTM 125 SMC R / Partial exhaust system / Slip-ON line / EC & ECE Type approval

PRODUCT CODE: S-KTM3SO7-HJMSS/1

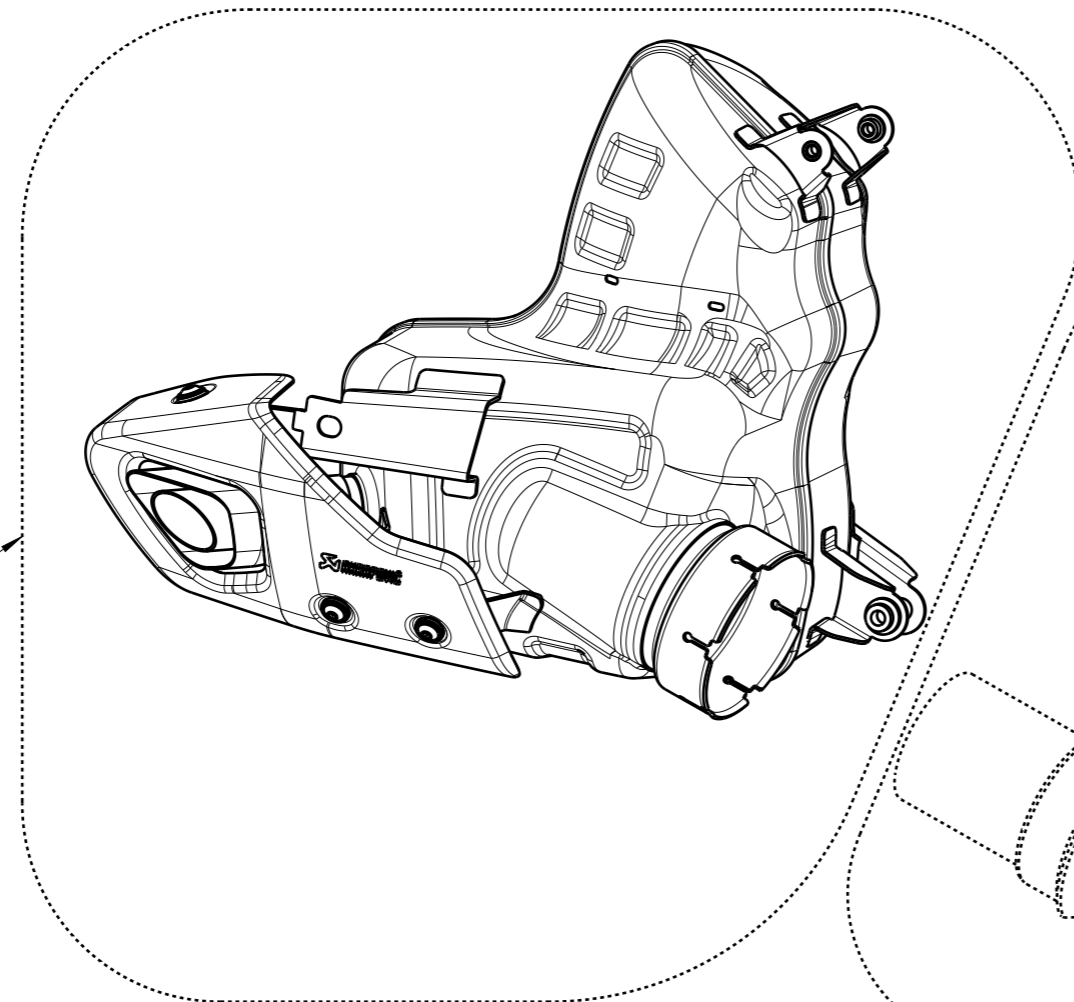
MUFFLER
M-HJM001
e26 08207 G
E26 92R-02 8207



ORIGINAL PARTS
with catalytic converter

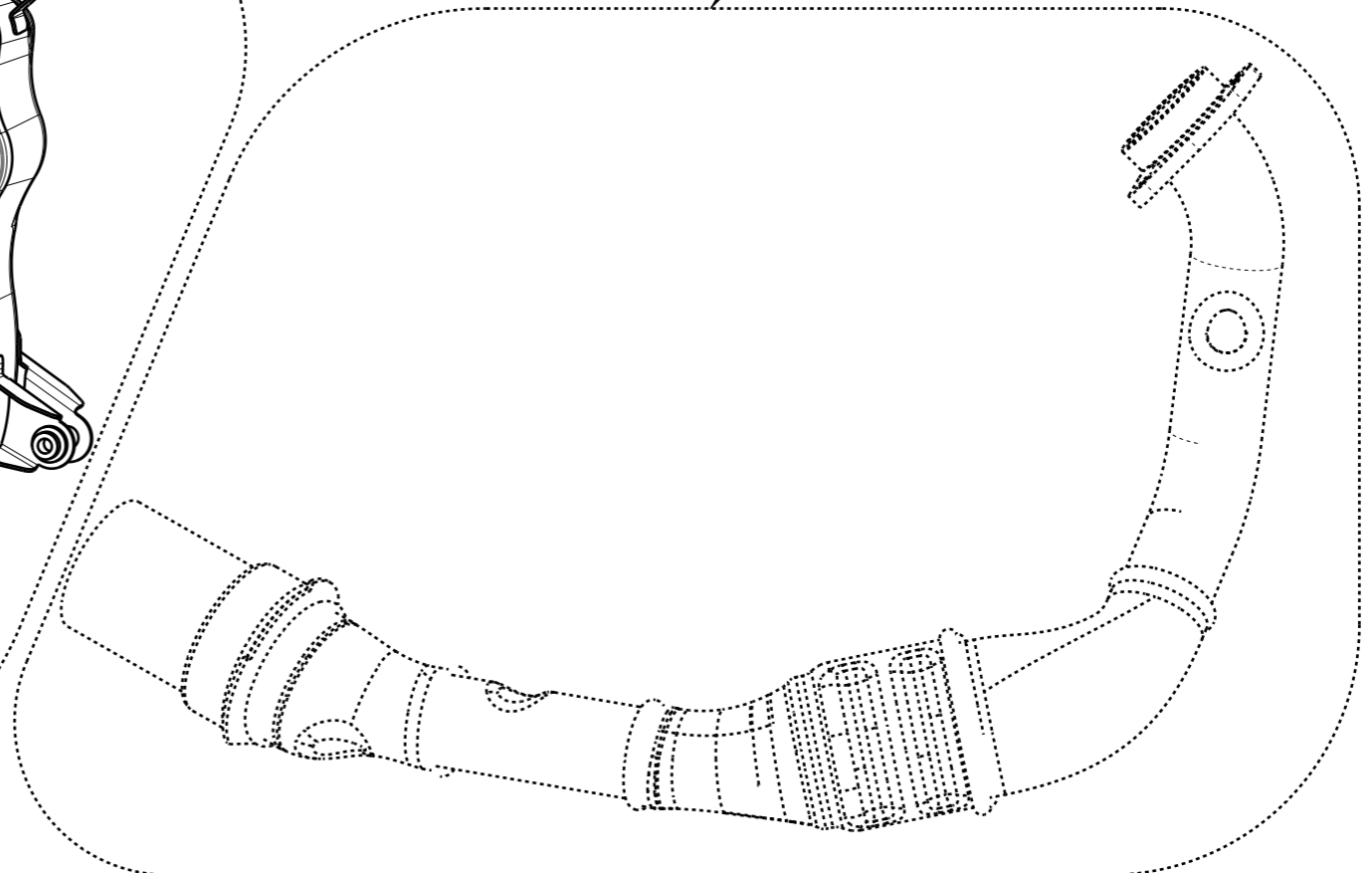



AVP, Kotnikova ulica 19a, SI-1000 Ljubljana, tel.: 01 478 8430, vozila@avp-rs.si
STSA, Kotnikova ulica 19a, SI-1000 Ljubljana, tel.: +386 1 478 8430, vozila@avp-rs.si
37141-53/2025/3

POTRDILO O EU-HOMOLOGACIJI
EU TYPE-APPROVAL CERTIFICATE

Sporočilo o:
Communication concerning:

~~-EU homologaciji~~
~~- EU type approval~~
~~- razširitvi EU-homologacije~~
~~- extension of EU type approval~~
~~- zavrnitvi EU-homologacije~~
~~- refusal of EU type approval~~
~~- preklicu EU-homologacije~~
~~- withdrawal of EU type approval~~

samostojne tehnične enote: naprave za zmanjševanje hrupa
of a type of STU: noise-abatement device

glede na Priloge IX k Delegirani uredbi Komisije (EU) št. 134/2014, kakor je bila nazadnje spremenjena z Delegirano uredbo Komisije (EU) št. 2023/2724
with regard to Annex(es) IX to Commission Delegated Regulation (EU) No 134/2014, as last amended by Commission Delegated Regulation (EU) No 2023/2724

Številka EU-homologacije: **e26*134/2014*2023/2724G*08207*01**
EU type approval number:

Razlog za razširitev:
Reason for extension:

razširitev področja uporabe
extended field of application

ODDELEK I
SECTION I

0.7	Znamke (tovarniška imena proizvajalca): <i>Make(s) (trade name(s) of manufacturer)</i>	AKRAPOVIČ
0.8	Tip: <i>Type:</i>	M-HJM001
0.8.1	Trgovska imena (če obstajajo): <i>Commercial name(s) (if available):</i>	/
0.9	Ime podjetja in naslov proizvajalca: <i>Company name and adress of manufacturer:</i>	AKRAPOVIC D.D. MALO HUDO 8A 1295 IVANCNA GORICA Slovenia

-
- 0.9.1. Imena in naslovi proizvodnih tovarn:
Name(s) and address(es) of assembly plant(s): AKRAPOVIC D.D.
MALO HUDO 8A
1295 IVANCNA GORICA
Slovenia
- AKRAPOVIČ D.D., PE ČRNOMELJ
ULICA HEROJA STARIHA 24
8340 ČRNOMELJ
Slovenia
- 0.9.2. Ime in naslov zastopnika
proizvajalca (če obstaja):
*Name and address of manufacturer's
representative (if nay):* /
- 0.10. Pri samostojni tehnični enoti,
vozila, za katere je namenjena:
*In the case of seperate technical unit,
vehicle(s) for which is intended for:* KTM
Husqvarna
- 0.10.1. Tip:
Type: glej poročilo o preskusu
see the test report
- 0.10.2. Variante:
Variant(s): vse
all
- 0.10.3. Izvedenke:
Version(s): vse
all
- 0.10.4. Trgovska imena (če obstajajo):
Commercial name(s) (if available): glej poročilo o preskusu
see the test report
- 0.10.5. Kategorija, podkategorija in
podpodkategorija vozila:
*Category, subcategory and
sub-subcategory of vehicle:* L3e
L3e-A3

ODDELEK II
SECTION II

1. Tehnična služba, pristojna za izvajanje preskusov:
Technical service responsible for carrying out the tests: TÜV SÜD Auto Service GmbH
Westendstraße 199
D-80686 München
Germany
2. Datum poročil o preskusu:
Date of test report(s): 06.06.2025
3. Številka poročil o preskusu:
Number of test report(s): 23-00043-CM-GBM-01
4. Opombe:
Remarks: glej Dodatek
see Addendum
- 4a. Homologacija je:
The approval is: **razširjena**
extended
- 4a.1. Homologacija se podeli na podlagi člena 40
Uredbe (EU) št. 168/2013, tako da je njena
veljavnost omejena do: ne pride v poštev
*The approval is granted in accordance with Article
40 of Regulation (EU) No 168/2013 and its
validity is thus limited to:* *not applicable*
5. ~~Omejitve veljavnosti:~~
~~*Restrictions of validity:*~~ /
6. ~~Uporabljene opustitve:~~
~~*Waivers applied:*~~ /
- Kraj:
Place: 1000 LJUBLJANA
- Datum:
Date: 18.06.2025
- Ime in podpis:
Name and signature: mag.Tomaž Svetina, univ.dipl.inž.str.
vodja sektorja za vozila

Temu sporočilu je priložen seznam dokumentov, ki so deponirani pri homologacijskem organu, ki je odobril to homologacijo in jih je na zahtevo mogoče dobiti:

glej kazalo opisne dokumentacije št. e08207 Rev.01

The list of documents deposited with the Administrative Service which has granted approval is annexed to this communication and may be obtained on request:

see index to information package No e08207 Rev.01

Dodatek k potrdilu o EU-homologaciji s številko EU-homologacije:
Addendum to the EU type-approval certificate with EU type-approval number:
e26*134/2014*2023/2724G*08207*01

1. **Omejitve uporabe samostojne tehnične enote: naprave za zmanjševanje hrupa:**
Restriction of use of the STU: noise-abatement device:

glej prilogo 2 testnega poročila 23-00043-CM-GBM-01
see enclosure 2 of the test report 23-00043-CM-GBM-01

2. **Posebni pogoji za vgradnjo samostojne tehnične enote: naprave za zmanjševanje hrupa:**
Special conditions for the mounting of the STU: noise-abatement device:

glej proizvajalčeva navodila za vgradnjo
see manufacturer's instruction manual

3. **Opombe:**
Remarks:

/

Ta homologacija se uporablja za tip serijsko izdelanih neoriginalnih izpušnih sistemov za tip motornega kolesa ali njegovih sestavnih delov pod naslednjimi pogoji:

Posamezni proizvodi iz serijske proizvodnje morajo ustrezati najmanj vsem zahtevam Uredbe (EU) št. 168/2013 in Priloge IX k Delegirani uredbi Komisije (EU) št. 134/2014, nazadnje spremenjene z Delegirano uredbo Komisije (EU) št. 2023/2724, "Zahteve za preskus tipa IX: raven hrupa".

Priloženo poročilo o preskusu in risbe so sestavni del te homologacije.

Vsak sestavni del neoriginalnega izpušnega sistema, vendar ne deli in cevi za vgradnjo, mora biti čitljivo in trajno označen z:

- znamko (tovarniškim imenom proizvajalca),
- trgovskim imenom,
- homologacijsko oznako.

Temu tipu proizvoda se dodeli naslednja homologacijska oznaka:

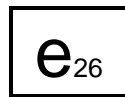

08207G

Homologacijska oznaka na proizvodu mora po izvedbi in velikosti ustrezati zahtevam Izvedbene uredbe Komisije (EU) št. 901/2014, nazadnje spremenjene z Izvedbeno uredbo Komisije (EU) št. 2023/2724.

S tem homologacijskim znakom so lahko označeni samo tisti proizvodi, ki v celoti ustrezajo homologacijski dokumentaciji.

Oznaka EU-homologacije samostojne tehnične enote ali sestavnega dela mora biti na samostojni tehnični enoti ali sestavnem dele nameščena tako, da je neizbrisna (npr. odtisnjena, jedkana, lasersko vgravirana, samouničljiva nalepka), jasno berljiva in vidna na mestu, kjer se namesti na vozilo, ne da bi bilo treba kateri koli del odstraniti z orodjem.

Proizvod je lahko označen tudi s tujo homologacijsko ali drugo oznako, če s tem ni motena razpoznavnost in čitljivost homologacijske oznake, ki jo je dodelil slovenski homologacijski organ.

Na proizvodu ne sme biti oznak, ki bi lahko privedle do zamenjave z uradno dodeljeno oznako.

Kakršnekoli spremembe na proizvodu so dovoljene samo na podlagi posebnega dovoljenja homologacijskega organa.

Veljavnost homologacije preneha z vrnitvijo ali z odvzemom. Homologacija se odvzame, če pogoji za podelitev in obstoj homologacije ne obstajajo več, če lastnik homologacije krši obveznosti, povezane s homologacijo, oziroma če se ugotovi, da homologirani proizvod ne ustreza več veljavnim predpisom.

Proizvajalec je dolžan stalno kontrolirati kakovost homologiranega proizvoda in njegovo skladnost s homologacijsko dokumentacijo. O tej kontroli je dolžan voditi evidenco in omogočiti vpogled v zapiske nadzornemu organu, ki ga določi homologacijski organ. V primeru ugotovitve neskladnosti s homologacijsko dokumentacijo je proizvajalec dolžan o tem takoj obvestiti homologacijski organ.

Homologacijski organ lahko kadarkoli preverja pravilno izvajanje pooblastil, dodeljenih s to homologacijo, in v ta namen tudi izbira vzorce za ponovni preskus. Stroške takšnih pregledov in presoj skladnosti proizvodnje, se zaračunajo proizvajalcu.

Vsako spremembo oznake proizvajalca, naslova ali proizvodne tovarne oziroma pri homologaciji imenovane pooblaščenice je treba takoj sporočiti homologacijskemu organu.

Pravice, podeljene s to homologacijo, so neprenosljive. Pravice tretjih s to homologacijo niso prizadete.

V primerih, da se proizvodnja ali prodaja proizvoda ne začne v roku enega leta od podelitve homologacije, da se proizvodnja ali prodaja prekine za več kot eno leto oziroma, da se predvideva taka prekinitev, je o tem treba takoj obvestiti homologacijski organ.

O začetku proizvodnje ali začetku prodaje oziroma njihovem ponovnem začetku je treba obvestiti homologacijski organ najkasneje v enem mesecu.

Neupoštevanje zgoraj navedenih določil lahko povzroči odvzem homologacije in se kazensko preganja.

Pravno razlago v zvezi s to homologacijo lahko daje samo homologacijski organ.

18.06.2025

mag. Tomaž Svetina, univ.dipl.inž.
vodja sektorja za vozila

This Approval shall apply to non-original exhaust systems for a type of motorcycle or its components from serial production under the following conditions:

Individual products from serial production shall comply at least with all requirements set out in the Regulation (EU) No 168/2013 and Annex(es) IX to Commission Delegated Regulation (EU) No 134/2014, as last amended by Commission Delegated Regulation (EU) No 2023/2724, "Test type IX requirements: sound level".

The attached test report and drawings shall be a constituent part of this Approval.

Each component of the nonoriginal exhaust system, excluding pipes and fitting accessories, shall be marked with a readable and durable:

- *make (trade name of manufacturer),*
- *commercial name,*
- *approval marking.*

This type of product shall be allotted the following approval marking:

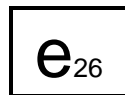

08207G

The design and size of the approval marking shall meet the requirements of the Commission implementing Regulation (EU) No 901/2014, as last amended by Commission implementing Regulation (EU) No 2023/2724.

Only products which comply with the approval documentation may bear the approval marking.

The EU separate technical unit or component type-approval mark shall be affixed to the separate technical unit or component in a way which is indelible (e.g. stamped, etched, laser-engraved, self-destructing adhesive label), clearly legible and visible in the place at which it is to be fitted to the vehicle without the need to remove any parts with the use of tools.

The product may also be marked with a foreign approval or other marking, provided that the identifiability and readability of the approval marking granted by the Slovenian Type Approval Authority is not affected.

The product shall not bear any markings that may lead to confusion with the officially allotted marking.

Changes of any kind performed on the product shall be subject to special permission by the Slovenian Type Approval Authority.

The Approval will become ineffective when returned or withdrawn. The Approval shall be withdrawn: should the conditions for its granting and existence no longer exist, should the owner of the Approval break his obligations related to the Approval, or when it has been established that the approved product no longer complies with the applicable regulations.

The manufacturer shall regularly inspect the quality of the approved product as well as its conformity with the approval documentation. He shall keep record of this inspection and allow to the surveillance body appointed by the Slovenian Type Approval Authority access to the records. Should any non-conformities be found with respect to the approval documentation, the manufacturer shall immediately inform thereof the Slovenian Type Approval Authority.

Any time, the Slovenian Type Approval Authority may check the correct implementation of the authorizations appointed through this Approval, and for this purpose also select samples for a repeated

test. The costs of such checks and conformity of production assessments are charged to the manufacturer.

Any changes regarding the manufacturer's marking, the address or the production plant, or the authorized person appointed through this Approval, shall be forthwith notified to the Slovenian Type Approval Authority.

The rights granted through this Approval shall be untransferrable. The rights of third persons shall not be affected through this Approval.

In the case where the production or sale of the product does not start within one year after the granting of the Approval, or the production or sale is interrupted for a period longer than one year, or such interruption is foreseen, the Slovenian Type Approval Authority shall be immediately notified.

The Slovenian Type Approval Authority shall be notified of the start of production or start of sale, or its restart, within a month's time at the latest.

Non-compliance with above stated provisions may result in withdrawal of the Approval and will be prosecuted.

Legal explanations in relation with this Approval may only be given by the Slovenian Type Approval Authority.

18.06.2025

Tomaž Svetina, M.Sc.Eng.
Head of Vehicle department